

### Product Character

- Multilayer Metal -Silicon Potential Structure.
- Low Leakage Current.
- High Current Capability, High Efficiency.
- High Junction Temperature Capability.
- RoHs Product.

### Primary Use

- Low Voltage High Frequency Switching Power Supply.
- Low Voltage High Frequency Invers Circuit.
- Low Voltage Continued Circuit and Protection Circuit.

### Summarize

- MBRT10150CD Device optimized for ultra-low forward voltage drop to maximize efficiency in Power Supply applications.

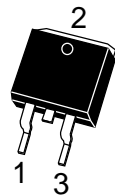

Package:TO-263-2L  
MBRT10150CD  
MBRT10150CD-HF  
HF=Halogen Free

### Equivalent Circuit

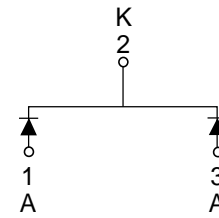

### Absolute Maximum Ratings

Item	Symbol	Data	Unit
Maximal Inverted Repetitive Peak Voltage	$V_{RRM}$	150	V
Average Rectified Forward Current (Rated VR-20Khz Square Wave) - 50% duty cycle	$I_{FAV}$	10	A
Forward Peak Surge Current(Rated Load 8.3 Half Mssine Wave-According to JEDEC Method)	$I_{FSM}$	190×2	A
Operating Junction Temperature	$T_J$	-40~150	°C
Storage Temperature	$T_{STG}$	-40~150	°C
Typical Thermal Resistance(per leg)	Package=TO-263-2L $R_{\theta JC}$	2	°C/W

### Electricity Character

Item	Test Condition		Value(min)	Value(typ)	Value(max)	Unit
$V_B$	$T_J = 25^\circ C$	$I_R = 1mA$	150	---	---	V
$I_R$	$T_J = 25^\circ C$	$V_R = 150V$	---	---	0.01	mA
	$T_J = 125^\circ C$	$V_R = 150V$	---	---	10.00	mA
$V_F$	$T_J = 25^\circ C$	$I_F = 5A$ ( $I_{FAV} = 5A \times 2$ )	---	0.8	0.9	V
	$T_J = 125^\circ C$		---	---	0.75	V



**Characteristic Curves**

**The forward voltage and forward current curve**

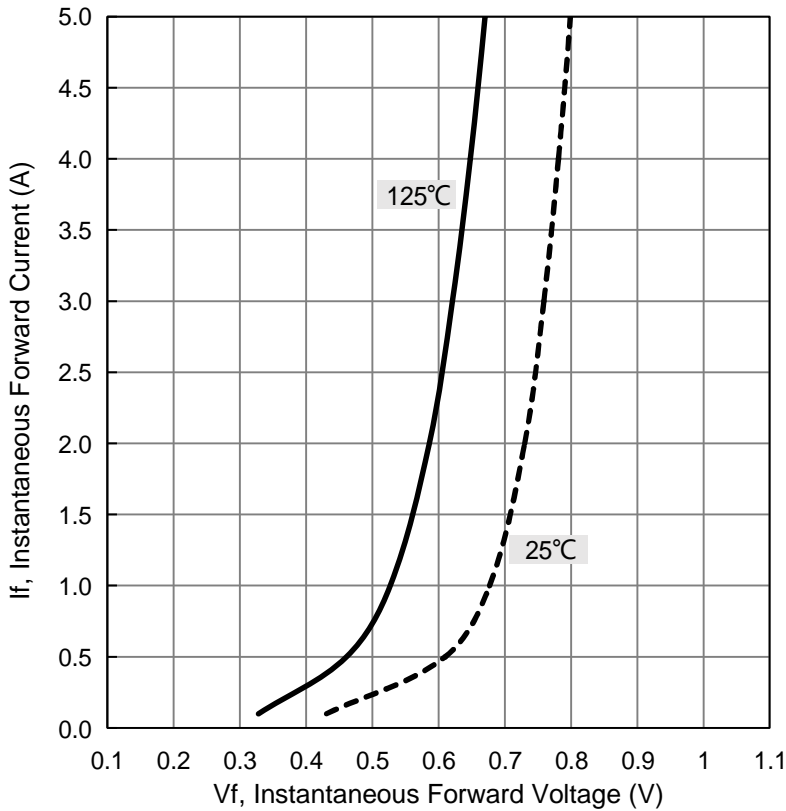

**Current derating curve, per element**

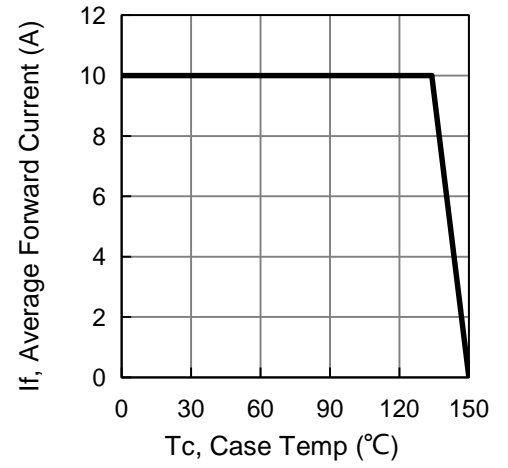

**The reverse leak current and the reverse voltage (single-device) curve.**

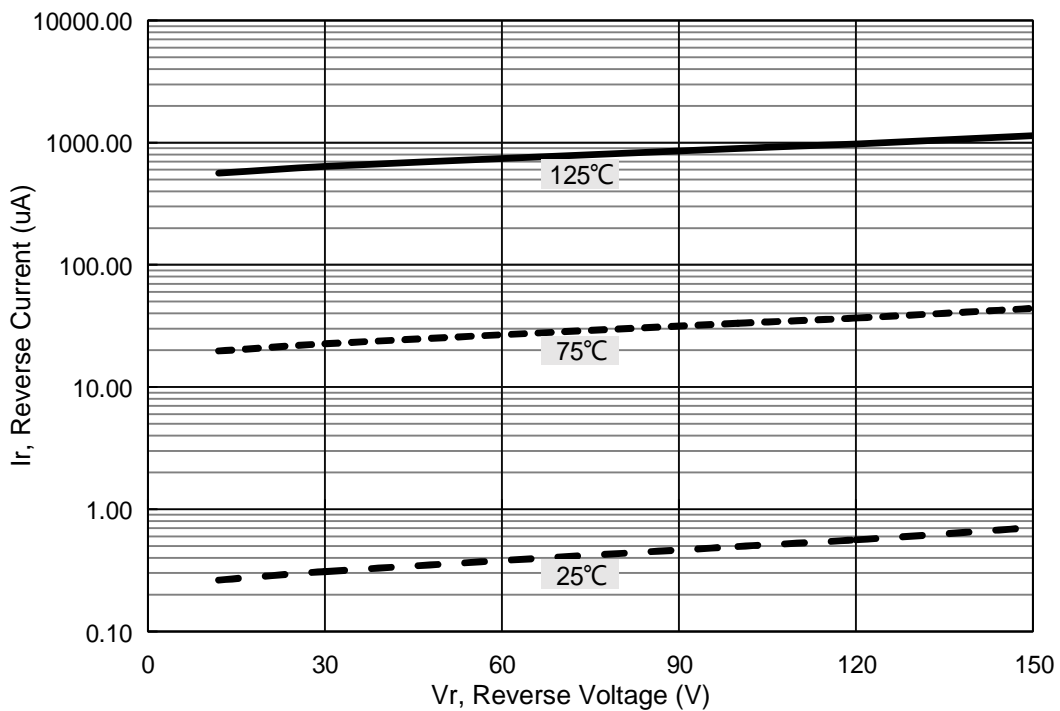



Package Outline Dimensions

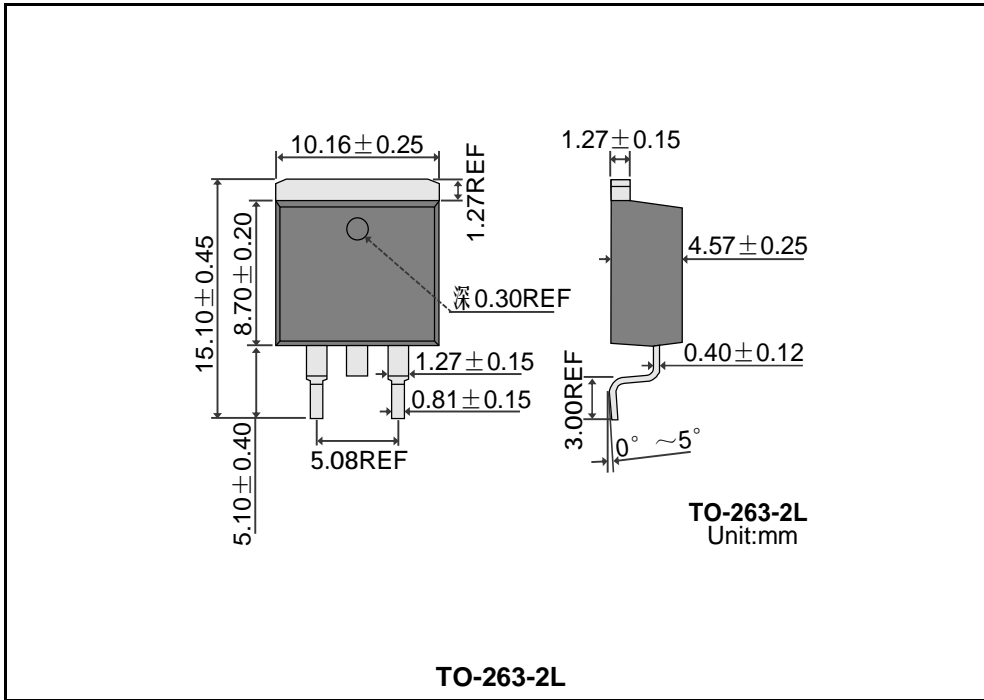

Marking Information

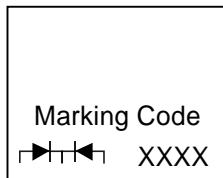

“Marking Code”= The Following  
“XXXX”= Date Code Marking

Package	Marking Code	Part Number
TO-263-2L	MBRT10150CD	MBRT10150CD
		MBRT10150CD-HF

Packing Information

Packaging	Package	Part Number	Quantity	Size
Tube	TO-263-2L	Tube	50 pieces	530*33*7mm
		Inner Box	1000 pieces	558*150*40mm
		Outer Box	5000 pieces	570*235*170mm
Reel	TO-263-2L	Reel	800 pieces	330*30mm
		Inner Box	800 pieces	345*345*35mm
		Outer Box	8000 pieces	375*375*350mm